

UNCLASS
CF-105 SERVICE DATA

AVR
Section 40
Electronics

3 Sept 66
ABully
Power Distribution

ANALYZED

CONFIDENTIAL

ANALYZED

CONFIDENTIAL

CF-105 SERVICE DATA

Classification cancelled / Changed to UNCLASS

By authority of AVES

Date 27 Sept 96

Signature [Signature]

Unit / Rank / Appointment AVES

ELECTRONICS
Section 40
POWER DISTRIBUTION

TABLE OF CONTENTS

TITLE	PAGE
SYSTEM SERVICE DATA	
DESCRIPTION	
General	3
JB R1	3
JB R2	4
FUNCTION TEST (To be issued later)	
INSPECTION (To be issued later)	
COMPONENT SERVICE DATA	
Power Junction Box R1	5
Junction Box R2	7

LIST OF ILLUSTRATIONS

FIGURE	TITLE	PAGE
1	Power Junction Box R1 - Schematic wiring	2

CF-105 SERVICE DATA

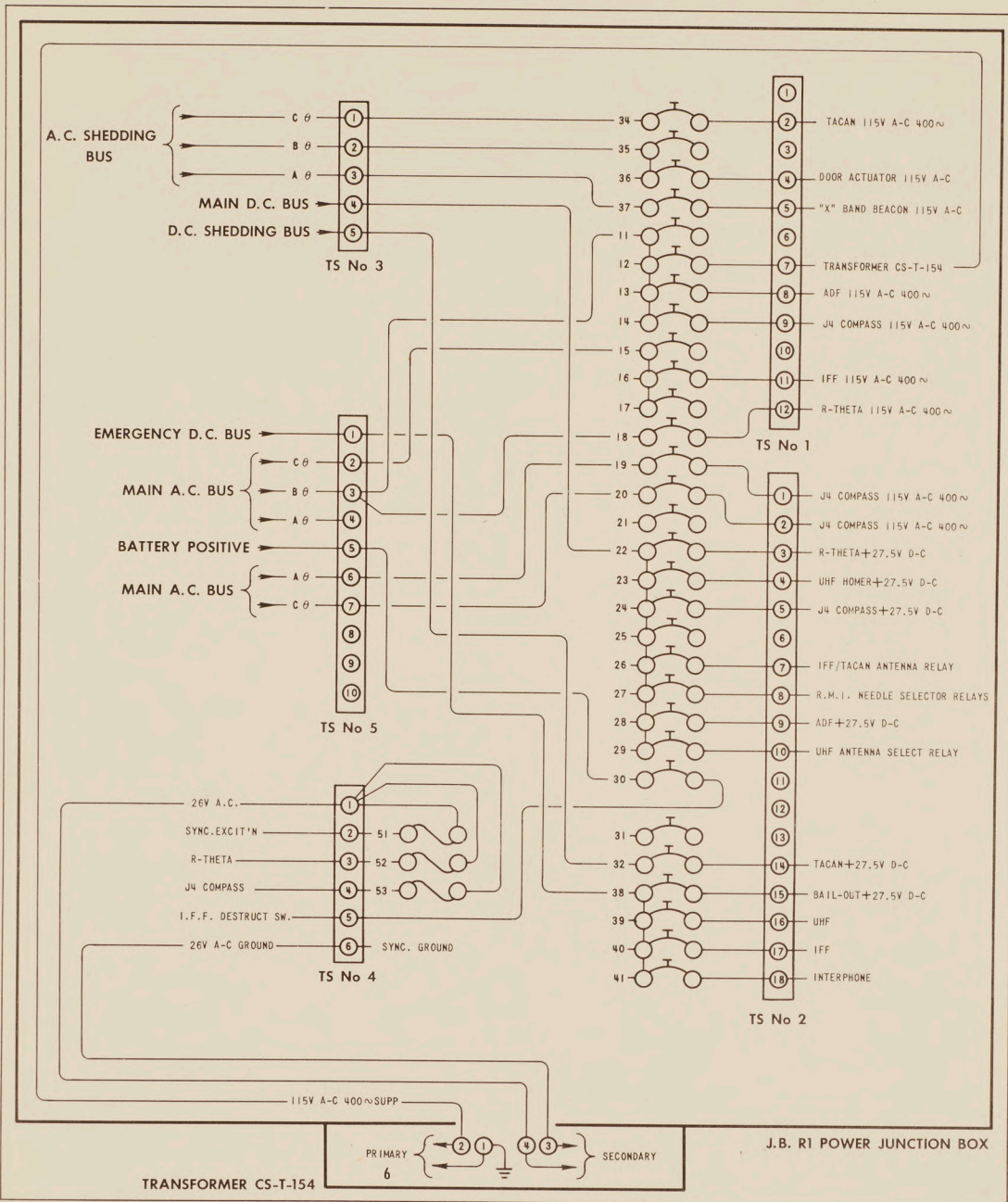

FIG. 1 POWER JUNCTION BOX R 1-SCHEMATIC WIRING

7M1-7019-1

7M1-343-2-2

CF-105 SERVICE DATA
SYSTEM DATA SHEET

SYSTEM	SUB-SYSTEM	AIRCRAFT EFF'TY	REF. NO.																																																																																																				
ELECTRONICS	POWER DISTRIBUTION	25201	13-10																																																																																																				
<p>DESCRIPTION</p> <p>General</p> <p>1. Two junction boxes designated JB R1 and JB R2 are provided to facilitate interconnection between the electronic systems components and aircraft power supplies.</p> <p>Junction Box R1</p> <p>2. Junction box R1, located in the electronic equipment bay on the bulkhead at Sta. 255, serves as the power distribution box. All electronics system power supply circuit breakers and fuses are housed in the junction box. Five terminal strips mounted inside the box facilitate interconnection between aircraft power supplies and the individual electronic systems. Mounted externally on the junction box is a 115/26 volt transformer type CS-T-154. The transformer derives a supply from the main a-c bus, and provides 26 volts a-c 400 cps output. Listed below are the circuit breakers in JB R1 together with the associated equipment and power supply.</p> <table style="width: 100%; border-collapse: collapse; margin-top: 20px;"> <thead> <tr> <th style="text-align: left;"><u>C.B. No.</u></th> <th style="text-align: left;"><u>C.B. Value</u></th> <th style="text-align: left;"><u>Voltage</u></th> <th style="text-align: left;"><u>Source of Supply</u></th> <th style="text-align: left;"><u>Equipment Supplied</u></th> </tr> </thead> <tbody> <tr><td>22</td><td>5A</td><td>27.5V. d-c</td><td>MAIN D-C BUS</td><td>R-Theta</td></tr> <tr><td>23</td><td>5A</td><td>27.5V. d-c</td><td>MAIN D-C BUS</td><td>UHF Homer</td></tr> <tr><td>24</td><td>5A</td><td>27.5V. d-c</td><td>MAIN D-C BUS</td><td>J4 Compass</td></tr> <tr><td>25</td><td>5A</td><td>27.5V. d-c</td><td>MAIN D-C BUS</td><td>(Reserved for Air (Data Boom</td></tr> <tr><td>26</td><td>5A</td><td>27.5V. d-c</td><td>MAIN D-C BUS</td><td>IFF/TACAN Antenna Relay</td></tr> <tr><td>27</td><td>5A</td><td>27.5V. d-c</td><td>MAIN D-C BUS</td><td>RMI Needle Selector Relay</td></tr> <tr><td>28</td><td>10A</td><td>27.5V. d-c</td><td>MAIN D-C BUS</td><td>ADF</td></tr> <tr><td>29</td><td>5A</td><td>27.5V. d-c</td><td>MAIN D-C BUS</td><td>(UHF Antenna Selector (Relay</td></tr> <tr><td>30</td><td>10A</td><td>27.5V. d-c</td><td>BATTERY BUS</td><td>IFF Destructor</td></tr> <tr><td>32</td><td>5A</td><td>27.5V. d-c</td><td>D-C SHEDDING BUS</td><td>TACAN</td></tr> <tr><td>38</td><td>5A</td><td>27.5V. d-c</td><td>EMERGENCY D-C BUS</td><td>Bail-out</td></tr> <tr><td>39</td><td>25A</td><td>27.5V. d-c</td><td>EMERGENCY D-C BUS</td><td>UHF</td></tr> <tr><td>40</td><td>5A</td><td>27.5V. d-c</td><td>EMERGENCY D-C BUS</td><td>IFF</td></tr> <tr><td>41</td><td>5A</td><td>27.5V. d-c</td><td>EMERGENCY D-C BUS</td><td>Interphona</td></tr> <tr><td>34</td><td>5A</td><td>115-200V. a-c</td><td>Secondary A-C Bus (Shedding) C ϕ</td><td>TACAN</td></tr> <tr><td>35</td><td>5A</td><td>115-200V. a-c</td><td>Secondary A-C Bus (Shedding) B ϕ</td><td>Reserved for Doppler</td></tr> <tr><td>36</td><td>5A</td><td>115-200V. a-c</td><td>Secondary A-C Bus (Shedding) B ϕ</td><td>Door Actuator</td></tr> <tr><td>37</td><td>5A</td><td>115-200V. a-c</td><td>Secondary A-C Bus (Shedding) A ϕ</td><td>"X" Band Beacon</td></tr> <tr><td>11</td><td>5A</td><td>115-200V. a-c</td><td>Primary A-C Bus (Main) B ϕ</td><td>(Reserved for Air (Data Computer</td></tr> </tbody> </table>				<u>C.B. No.</u>	<u>C.B. Value</u>	<u>Voltage</u>	<u>Source of Supply</u>	<u>Equipment Supplied</u>	22	5A	27.5V. d-c	MAIN D-C BUS	R-Theta	23	5A	27.5V. d-c	MAIN D-C BUS	UHF Homer	24	5A	27.5V. d-c	MAIN D-C BUS	J4 Compass	25	5A	27.5V. d-c	MAIN D-C BUS	(Reserved for Air (Data Boom	26	5A	27.5V. d-c	MAIN D-C BUS	IFF/TACAN Antenna Relay	27	5A	27.5V. d-c	MAIN D-C BUS	RMI Needle Selector Relay	28	10A	27.5V. d-c	MAIN D-C BUS	ADF	29	5A	27.5V. d-c	MAIN D-C BUS	(UHF Antenna Selector (Relay	30	10A	27.5V. d-c	BATTERY BUS	IFF Destructor	32	5A	27.5V. d-c	D-C SHEDDING BUS	TACAN	38	5A	27.5V. d-c	EMERGENCY D-C BUS	Bail-out	39	25A	27.5V. d-c	EMERGENCY D-C BUS	UHF	40	5A	27.5V. d-c	EMERGENCY D-C BUS	IFF	41	5A	27.5V. d-c	EMERGENCY D-C BUS	Interphona	34	5A	115-200V. a-c	Secondary A-C Bus (Shedding) C ϕ	TACAN	35	5A	115-200V. a-c	Secondary A-C Bus (Shedding) B ϕ	Reserved for Doppler	36	5A	115-200V. a-c	Secondary A-C Bus (Shedding) B ϕ	Door Actuator	37	5A	115-200V. a-c	Secondary A-C Bus (Shedding) A ϕ	"X" Band Beacon	11	5A	115-200V. a-c	Primary A-C Bus (Main) B ϕ	(Reserved for Air (Data Computer
<u>C.B. No.</u>	<u>C.B. Value</u>	<u>Voltage</u>	<u>Source of Supply</u>	<u>Equipment Supplied</u>																																																																																																			
22	5A	27.5V. d-c	MAIN D-C BUS	R-Theta																																																																																																			
23	5A	27.5V. d-c	MAIN D-C BUS	UHF Homer																																																																																																			
24	5A	27.5V. d-c	MAIN D-C BUS	J4 Compass																																																																																																			
25	5A	27.5V. d-c	MAIN D-C BUS	(Reserved for Air (Data Boom																																																																																																			
26	5A	27.5V. d-c	MAIN D-C BUS	IFF/TACAN Antenna Relay																																																																																																			
27	5A	27.5V. d-c	MAIN D-C BUS	RMI Needle Selector Relay																																																																																																			
28	10A	27.5V. d-c	MAIN D-C BUS	ADF																																																																																																			
29	5A	27.5V. d-c	MAIN D-C BUS	(UHF Antenna Selector (Relay																																																																																																			
30	10A	27.5V. d-c	BATTERY BUS	IFF Destructor																																																																																																			
32	5A	27.5V. d-c	D-C SHEDDING BUS	TACAN																																																																																																			
38	5A	27.5V. d-c	EMERGENCY D-C BUS	Bail-out																																																																																																			
39	25A	27.5V. d-c	EMERGENCY D-C BUS	UHF																																																																																																			
40	5A	27.5V. d-c	EMERGENCY D-C BUS	IFF																																																																																																			
41	5A	27.5V. d-c	EMERGENCY D-C BUS	Interphona																																																																																																			
34	5A	115-200V. a-c	Secondary A-C Bus (Shedding) C ϕ	TACAN																																																																																																			
35	5A	115-200V. a-c	Secondary A-C Bus (Shedding) B ϕ	Reserved for Doppler																																																																																																			
36	5A	115-200V. a-c	Secondary A-C Bus (Shedding) B ϕ	Door Actuator																																																																																																			
37	5A	115-200V. a-c	Secondary A-C Bus (Shedding) A ϕ	"X" Band Beacon																																																																																																			
11	5A	115-200V. a-c	Primary A-C Bus (Main) B ϕ	(Reserved for Air (Data Computer																																																																																																			
ISSUE	1																																																																																																						
DATE	16 Jan 57																																																																																																						

TM-313-2-3

<u>C.B. No.</u>	<u>C.B. Value</u>	<u>Voltage</u>	<u>Source of Supply</u>	<u>Equipment Supplied</u>
12	5A	115-200V. a-c	Primary A-C Bus (Main) B ϕ	(Transformer CS-T-154 (115/26V. Primary ADF
13	5A	115-200V. a-c	Primary A-C Bus (Main) B ϕ	
14	5A	115-200V. a-c	Primary A-C Bus (Main) B ϕ	J4 Compass
15	5A	115-200V. a-c	Primary A-C Bus (Main) C ϕ	Reserved for Damping
16	5A	115-200V. a-c	Primary A-C Bus (Main) C ϕ	IFF
17	5A	115-200V. a-c	Primary A-C Bus (Main) C ϕ	(Reserved for Emergency (Damping
18	5A	115-200V. a-c	Primary A-C Bus (Main) B ϕ	R-Theta
19	5A	115V. a-c 400 cps	Primary A-C Bus (Main) A ϕ	J4 Compass
20	5A	115V. a-c 400 cps	Primary A-C Bus (Main) C ϕ	J4 Compass
51(F)	1.5A	26V. a-c	Transformer CS-T-154	Synchro. Excitation
52(F)	1.5A	26V. a-c	Transformer CS-T-154	R-Theta
53(F)	0.5A	26V. a-c	Transformer CS-T-154	J4 Compass

(F) Fuses

Junction Box R2

3. Junction Box R2, located on the forward face of the bulkhead at Sta. 255 in the electronic power bay, serves as the circuit interconnection point and relay panel. Twelve terminal strips mounted inside the box, and thirteen AN type connectors mounted around the sides of the box, facilitate interconnection between electronic systems components. Six type CS-R-131 relays, mounted in the junction box, control the operation of the following circuits:

- Relay No. 41 - Tow Vehicle Interphone.
- Relay No. 42 - Starting Vehicle Interphone.
- Relay No. 43 - IFF Aux. Mode 2 Control and UHF Transmit Control interlock.
- Relay No. 44 - Front cockpit RMI Needle Selector.
- Relay No. 45 - Rear cockpit RMI Needle Selector.
- Relay No. 46 - Telescramble Interphone.

ISSUE	1						
DATE	16 Jan 57						

TR-313-2-4

CF-105 SERVICE DATA
COMPONENT DATA SHEET

SYSTEM ELECTRONICS		SUB-SYSTEM POWER DISTRIBUTION		COMPONENT Power Junction Box R1		REF. NO. 13-10-1	
AVRO PART NO. 7-1354-43		MANUFACTURER Avro Aircraft		MAN'FR'S PART NO.		AIRCRAFT EFFECTIVITY 25201	
OVERHAUL LIFE :		KNOWN-		ESTIMATED-		1500 hours	
FUNCTION To serve as a power distribution point for the electronic systems.							
LOCATION Mounted in electronics equipment bay, on bulkhead 255.							
ACCESS Release and lower the electronics equipment bay centre access door - 33 camlocs.						MEN X MINUTES	
REPLACEMENT PROCEDURE Open the lid of the junction box and secure the lid retaining strut. Fit the box to the bulkhead using six mounting screws. Draw the circuit wires through the AN connector shells on the sides of the junction box and secure the wiring to the terminal strips. Release the lid retaining strut and close the lid of the junction box.						MEN X MINUTES	

781-3413-2-5

CONFIDENTIAL

INSPECTION		MEN X MINUTES	
<p>Check that the wiring, terminal strips and connector shells are securely and properly fitted.</p>			
FUNCTIONAL CHECKS		MEN X MINUTES	
GROUND HANDLING AND GROUND TEST EQUIPMENT			
SPECIAL TOOLS TO REMOVE OR SERVICE			
REMARKS			
ISSUE	1		
DATE	16 Jan 57		

TR-3913-2-4

CF-105 SERVICE DATA
COMPONENT DATA SHEET

SYSTEM ELECTRONICS		SUB-SYSTEM POWER DISTRICUTION		COMPONENT Junction Box R2		REF. NO. 13-10-2	
AVRO PART NO. 7-1352-11		MANUFACTURER Avro Aircraft		MAN'FR'S PART NO.		AIRCRAFT EFFECTIVITY 25201	
OVERHAUL LIFE:		KNOWN-		ESTIMATED-		1500 hours	
FUNCTION To facilitate interconnection of electronic systems components. Also houses six relays used in certain circuits.							
LOCATION Mounted on the forward face of bulkhead 255 in the electronics power bay.							
ACCESS Remove electronics power bay access panel by removing 76 - 3/16 inch screws.						MEN X MINUTES	
REPLACEMENT PROCEDURE Remove the lid of the junction box - 12 camloc fasteners. Fit and secure the junction box to the bulkhead at Sta. 255 - 12 screws. Connect and secure circuit wiring. Connect 13 AN connectors (R1020-2, R1012-5, R1007-4, R1014-3, R1023-1, R1009-3, R1021-1, R1006-2, R1051-3, R1013-2, R1052-2, R1010-5, R1024-1). Refit lid and secure 12 camloc fasteners.						MEN X MINUTES	

14-1313-2-5

CONFIDENTIAL

<p>INSPECTION</p> <p>Check that the wiring, relays and connectors are securely and properly fitted.</p>		<p>MEN X MINUTES</p>								
<p>FUNCTIONAL CHECKS</p>		<p>MEN X MINUTES</p>								
<p>GROUND HANDLING AND GROUND TEST EQUIPMENT</p>										
<p>SPECIAL TOOLS TO REMOVE OR SERVICE</p>										
<p>REMARKS</p>										
<p>ISSUE</p>	<p>1</p>									
<p>DATE</p>	<p>16 Jan 57</p>									

TM-3113-2-4

WANG
3556
MADE IN U.S.A.